



Optical Fiber Standards and Their Applications

Thiam Boon Kwee
FiberOpto Asia Pte Ltd



Agenda

- Optical Fiber at Work
- Major Categories of Optical Fiber
- Major Attributes of Optical Fiber
- International Standards for Optical Fibers
- Bend Insensitive Fiber Standards

Optical Fiber at Work

Since 1980s, optical fiber cable is slowly replacing copper cable as the mainstream medium of transmission in telecommunication network

From undersea submarine network, terrestrial long-haul, to metro backbone and access network

Now we are already beginning to see fibers running in the last mile and even into the subscriber's home. Fiber-to-the-Home (FTTH) has become an industrial buzzword. This is an umbrella term used for emerging access networks that uses optical fiber in the first/last mile.

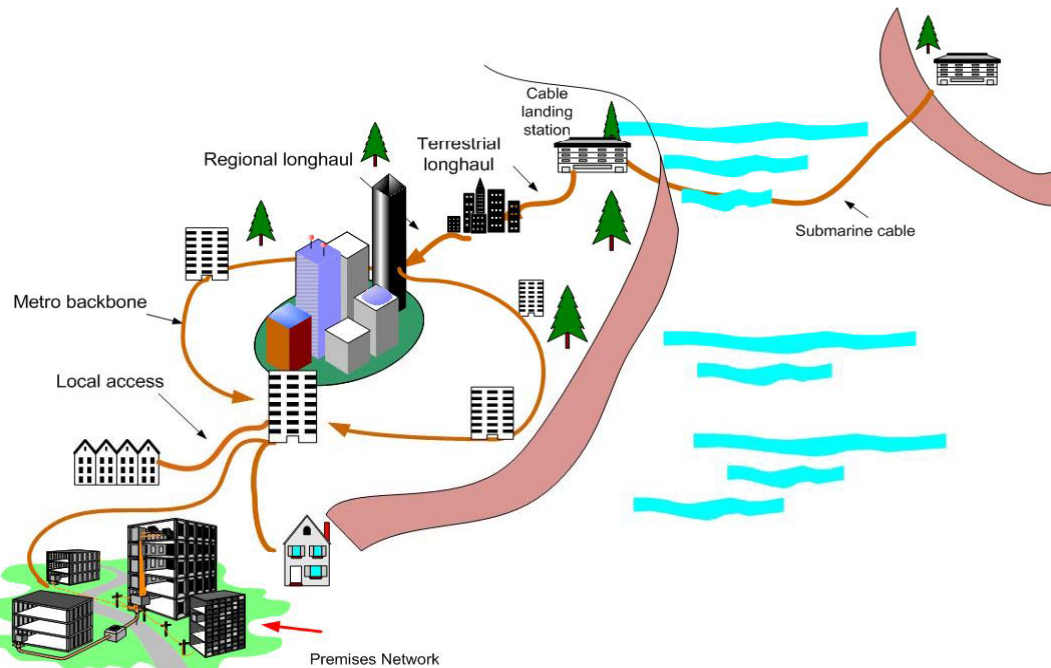

Major Categories of Optical Fibers

- Singlemode Fiber
- Multimode Fiber
- Specialty Fiber
- Plastic Optical Fiber

Singlemode or Multimode, Any One ?

Single-mode

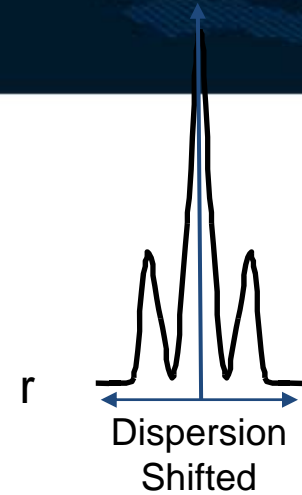
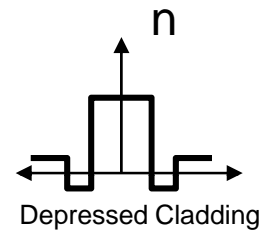
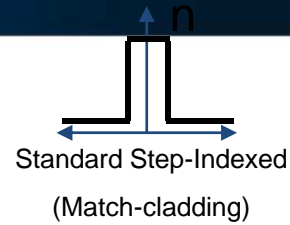
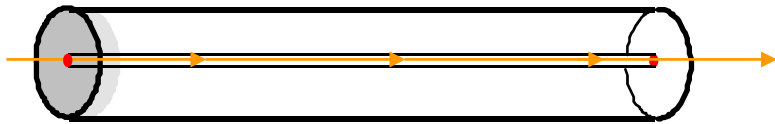

Refractive Index Profile

Multimode

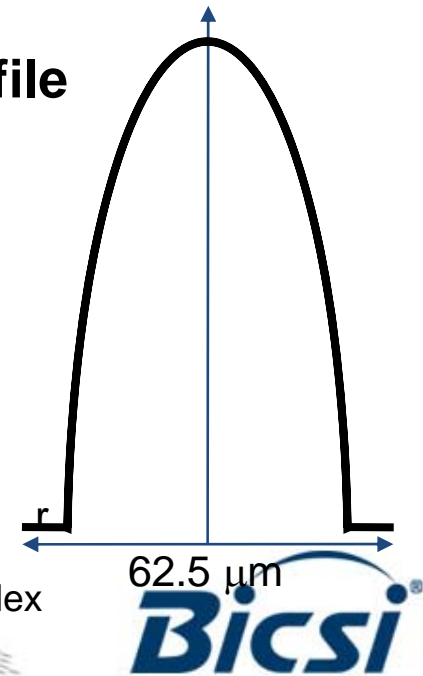
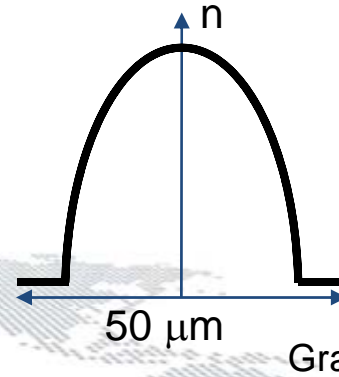
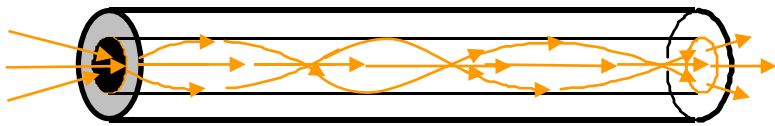

Types of Optical Fiber

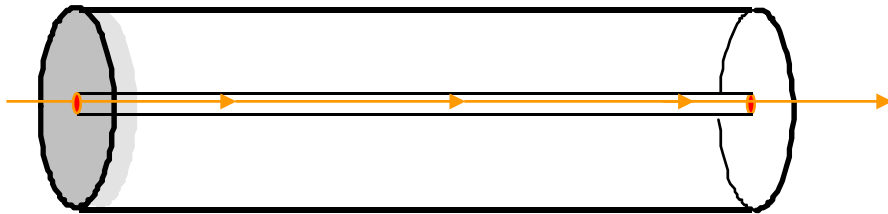

Single-mode

Single-Mode Fiber

It consists of smaller core and only allows one mode (or path) for light to travel

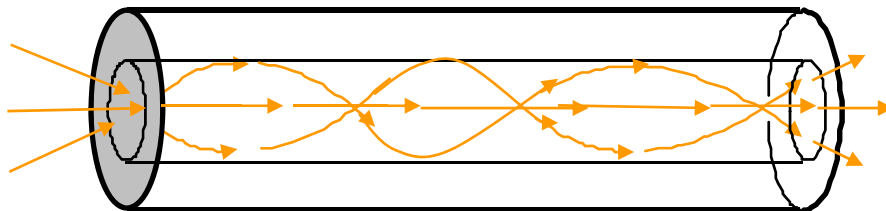

Multimode

Multimode Fiber

Its bigger core size allows multiple modes (or paths) of light to travel

Attenuation of Fiber

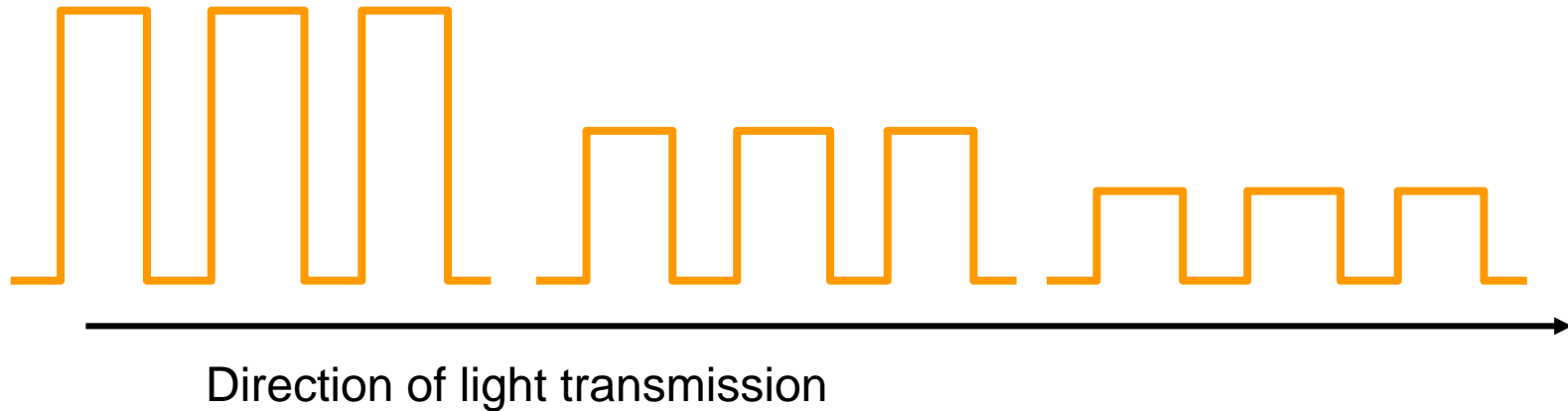

The attenuation is measured in dB/km

Power is measured in dBm = $10 \times \text{Log}_{10}$ (Power output in mW/1mW)

Loss is measured in dB = (Power output in dBm/Power input in dBm)

Note that 3dB loss means 50% of the power is loss

Major Attributes of Optical Fiber

- Attenuation
- Dispersion

Attenuation Curve of Optical Fiber (Attenuation versus Wavelength Curve)

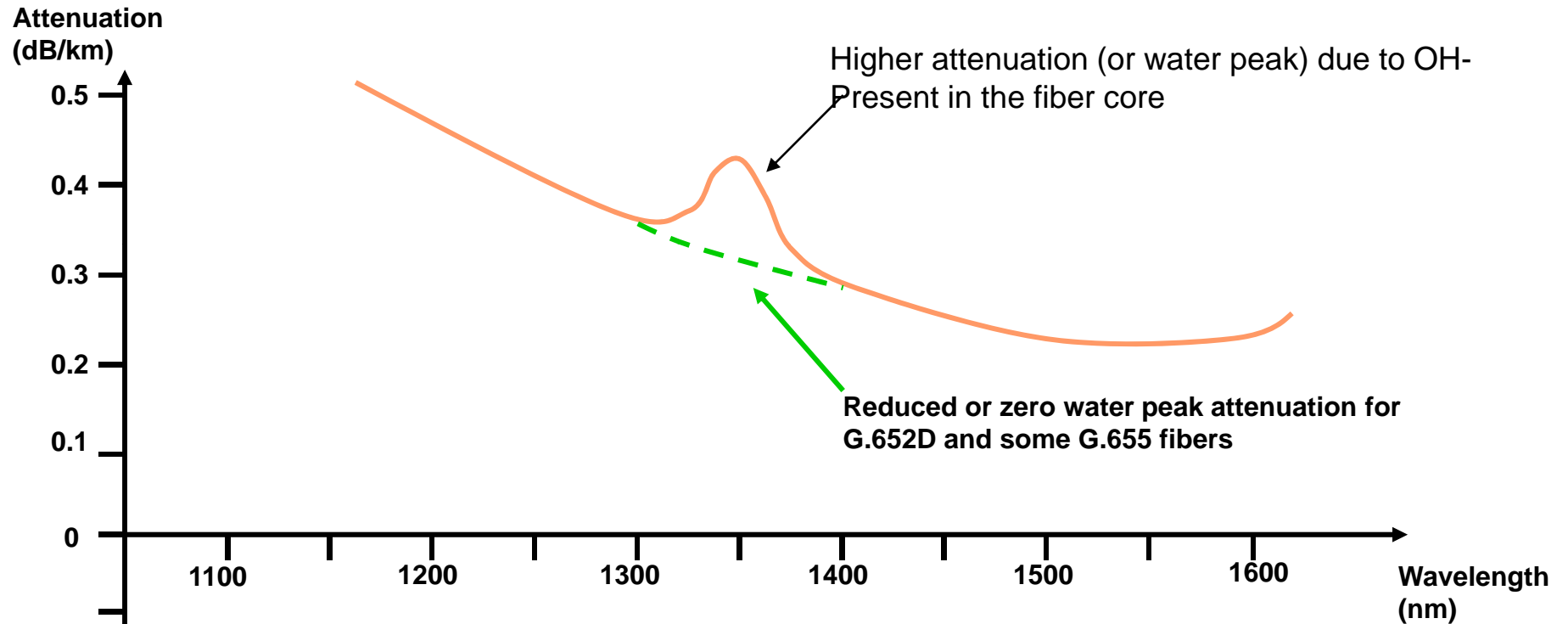

Dispersion

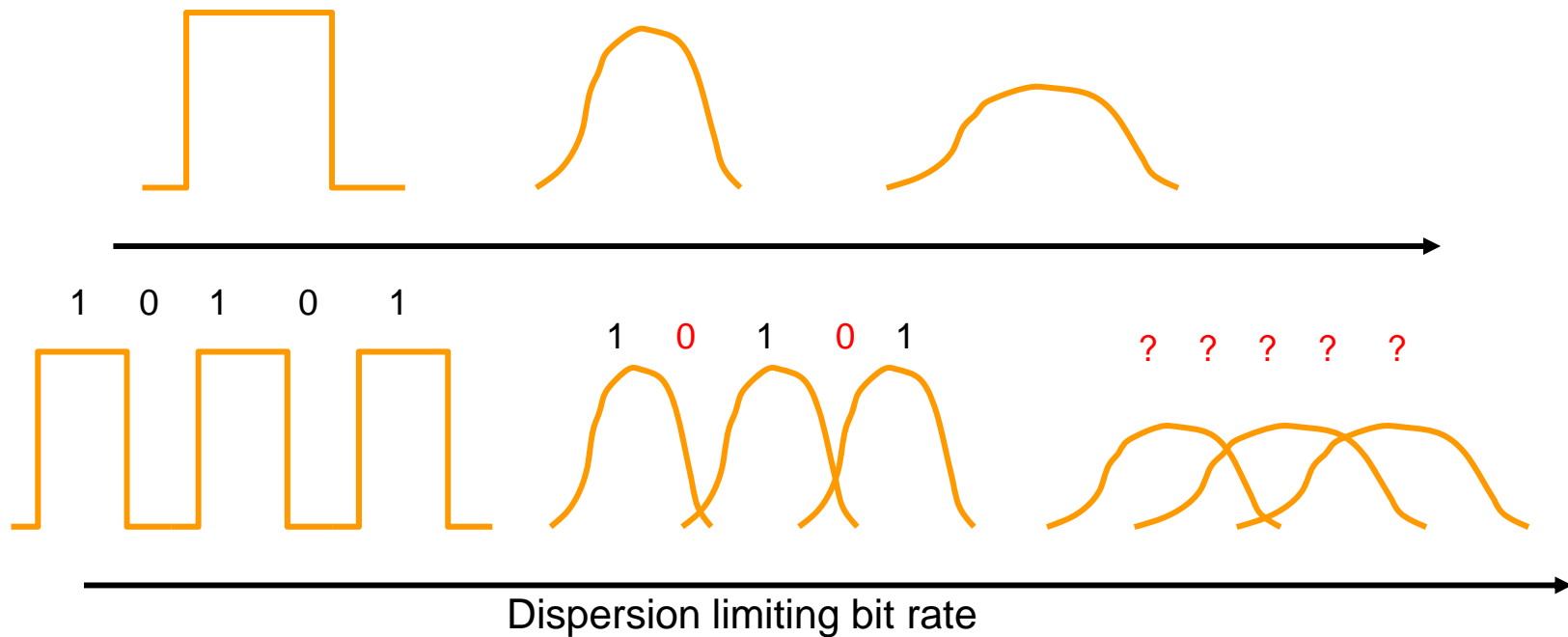

Dispersion is one of the unique characteristics of light wave transmission in glass (eg. Optical fiber, glass prism). This is not seen in electrical transmission in copper cable.

Dispersion refers to broadening of light pulse (in time domain) over time , therefore causing pulse distortion and therefore limiting the transmission speed

Different types of dispersions

(1) Modal dispersion

- Mainly in multimode fibers

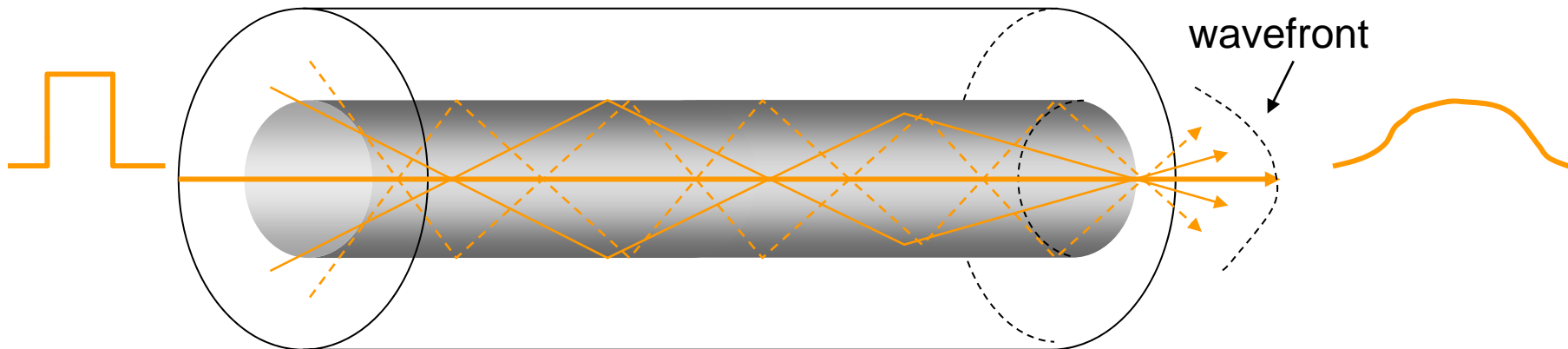

Light wave travels in different paths, thus different distances, and arriving at different times at the receiver, giving rise to modal dispersion

Graded index in multimode fiber attempts to mitigate this effect.

Dispersion Curve for Optical Fiber

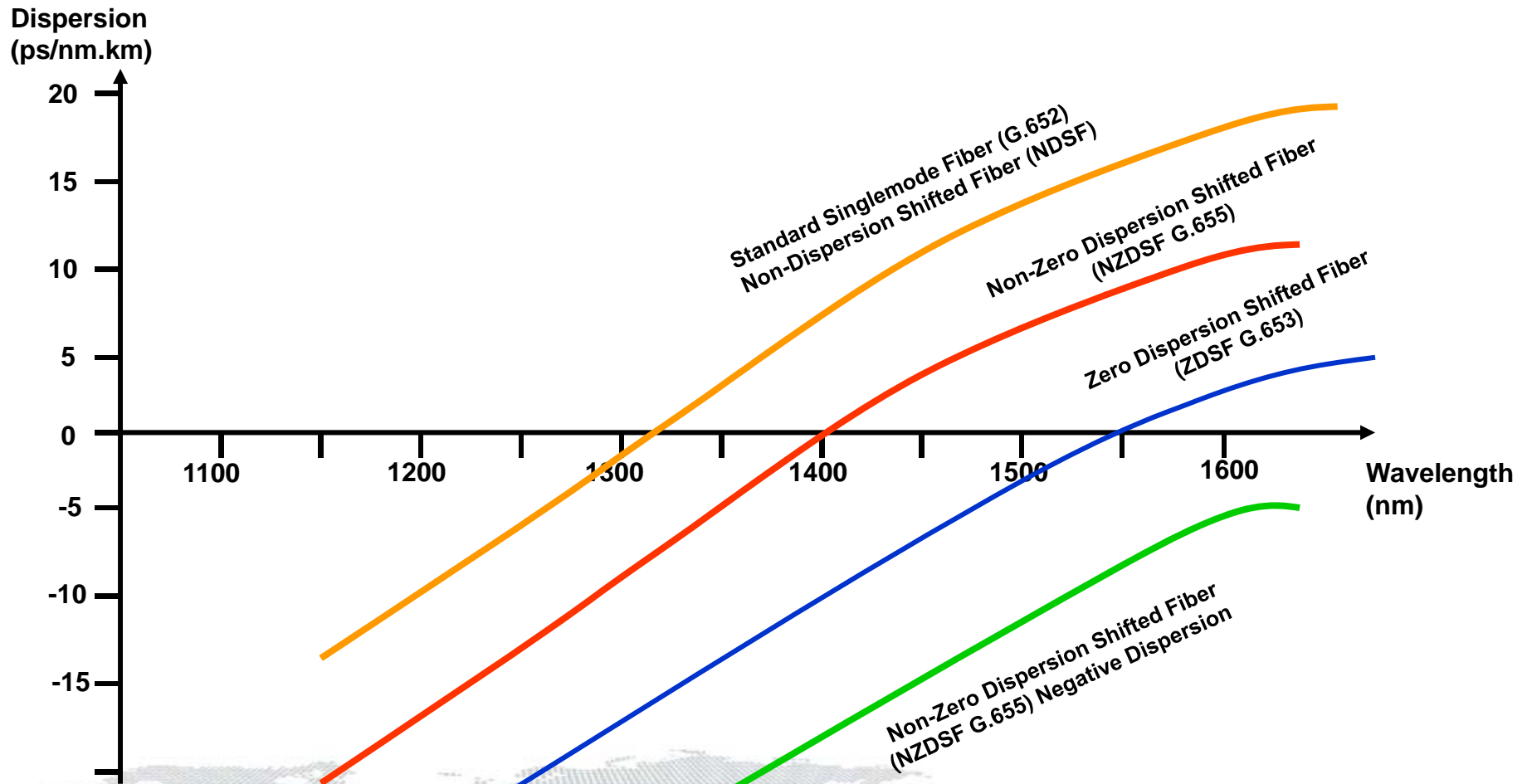

Components of Chromatic Dispersion

- material dispersion
- wavelength dispersion



More of the different fiber standards later

International Standards for Optical fiber

ITU-T G.651

Multimode fiber standard

ITU-T G.652

Standard Singlemode fiber. 4 different categories (A, B, C, D) differ in the water peak attenuation around the 1383nm window

Equivalent standards : Telcordia GR-20, IEC 60793-2, [TIA/EIA-492CAAB](#)

ITU-T G.653

Zero Dispersion Shifted Fiber (ZDSF), having zero dispersion around the 1550nm window

ITU-T G.654

Cutoff shifted and low attenuation fiber, designed mainly for submarine applications

ITU-T G.655

Non-zero Dispersion Shifted Fiber (NZDSF), having low dispersion in the 1550nm and 1625nm windows, the DWDM region. Suited for longhaul and backbone applications. Categories A, B, C, D, E differ in PMD and dispersion values

ITU-T G.656

Medium Dispersion Fiber (MDF), designed for local access and longhaul fiber

ITU-T G.657

Latest standard (from 2008 Jan) for FTTH application. Designed to bend at small radius of down to 10mm radius and 7.5mm radius



Bend Insensitive Fiber Standards

- The Need for Bend-Insensitive Fiber
- The Standards for Bend-Insensitive Fibers
- To Bend or Not to Bend, that is the Question



FTTH

In FTTH, fibre is “home-run” from exchanges all the way to the subscriber premises up to the Termination Point (TP) on the wall of the subscriber’s home





Sharp bend



Wall-mounted TP box (OpenNet)

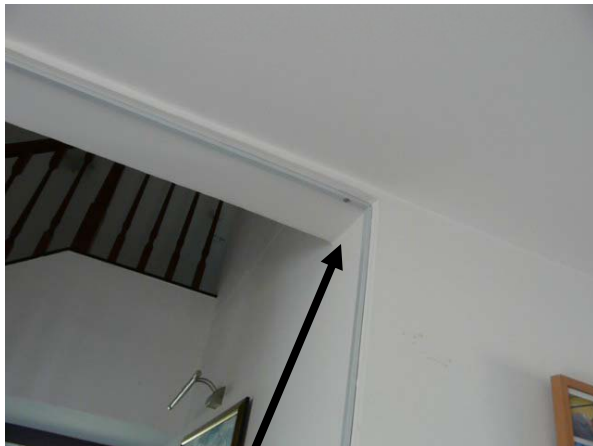

Sharp bend

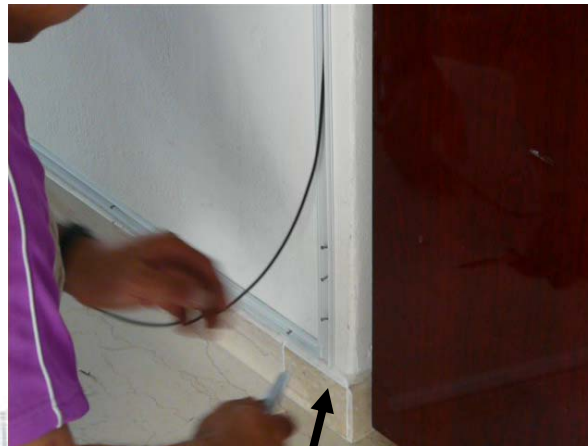

Sharp bend



FTTH

- Sharp bends are unavoidable in last mile cable installation in FTTH deployment
- Patch cord connecting TP point to ONT (Optical Network Terminal) also requires ruggedized bend-insensitive capability



Bicsi

Can We Defy Laws of Optics ?

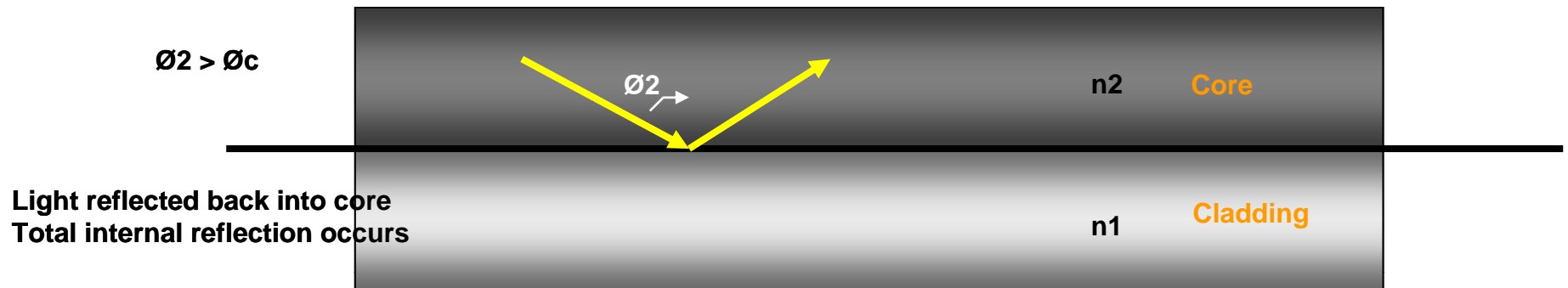

Light is guided through the fibre by law of total internal reflection

Moderate loss
with large
diameter bends

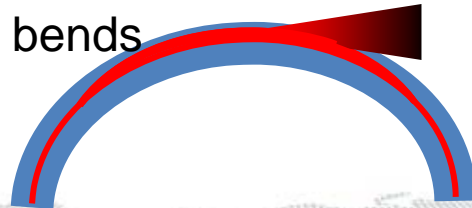

Increased loss with
tighter bends

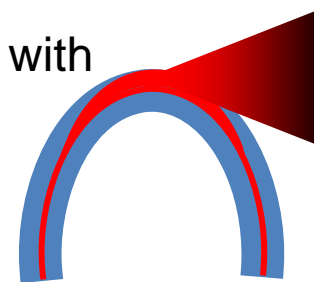

Multimode

- In enterprise network, multimode fiber is becoming more popular in the horizontal cabling in the Fiber-to-the-Zone (FTTZ) architecture
- Bandwidth is shifting from 1Gbps to 10Gbps, therefore shrinking the power loss budget

Standards for Bend Insensitive Fiber

Singlemode Fiber Standards

ITU-T G.657

Category A



Bend Radius	ITU-T G.657.A.1	ITU-T G.657.A.2	ITU-T G.657.A.3
10mm	0.75 dB/turn		
7.5 mm	-	0.5 dB/turn	
5 mm	-	-	0.15 dB/turn

Category A emphasize on backward compatibility with ITU-T G.652.D
Loss specified at 1550nm



Singlemode Fiber Standards

ITU-T G.657

Category B

Bend Radius	ITU-T G.657.B2	ITU-T G.657.A.2
7.5 mm	0.5 dB/turn	
5 mm	-	0.15 dB/turn

Category B need not be backward compatibility with ITU-T G.652.D
Loss specified at 1550nm



Multimode Fiber Standards

Bend Radius	IEC 60793-2-10	ITU-T G.651.1
37.5 mm	0.5 dB/100 turn	-
15 mm	-	1 dB/ 2 turn

Loss at 850nm

Currently there is no standard which define tighter bend radius for Multimode fibers

Bend insensitive multimode fiber, achieved by keeping most modes in the core of the fiber, may disturb the mode distribution vital in the high performance MMF such as OM3 and OM4

